



AIRTREND Limited
Predstavništvo u Beogradu
Kumanovska 14, 11000 Beograd
Tel: 011/3836886, 3085740
Faks: 011/3444113
e-mail: gobrid@eunet.rs
web: www.airtrend.rs

ENERGY EFFICIENT VENTILATION

Östberg is one of the leading producers of radial fans in the world. In the early 1970s, the founder and owner of the company designed the first circular and rectangular in-line radial duct fans in history with external rotor motors and straight-through airflow (180°). We have continued to develop new products and today offer a wide product range of centrifugal in-line duct fans, roof fans, wall fans and energy recovery units. Our goal is to always offer the highest-quality products at competitive prices. The company is certified according to the quality and environment standards ISO 9001 and ISO 14001. These high demands guarantee an efficient and rational production of high-standard fans. All our fans are tested before delivery, which gives us 100% control of production. Air quality directly affects the way we feel, not only physically but also mentally. Therefore use high-quality products from Östberg in order to achieve a healthy indoor climate with energy-efficient ventilation.



The following two symbols are used in this catalogue:



Products marked with the AC and EC symbols are approved for use in the EU, EFTA & EEA countries.

MECHANICAL

FILTERBOXES AND FILTERS.....	376
ASSEMBLY AND INSTALLATION	378

ELECTRICAL

CONTROLLERS AND REGULATORS	384
SENSORS	388
TIMERS	389
MOTOR PROTECTION.....	390

FOR ATEX

FOR ATEX CERTIFIED FANS.....	392
------------------------------	-----

FOR ROOF FANS

ROOF CURBS.....	396
-----------------	-----

MECHANICAL ACCESSORIES

FILTERBOXES AND FILTERS

FILTERBOX, FLK

The FLK filterbox is manufactured from galvanized steel sheet. It is delivered with a G4 filter.

FILTER to FLK

The FLK filters are designed for use in the FLK filter boxes. There are two different filter types to choose from: standard (Mod96) and cleanable filters. Cleanable filters are easy to clean and are commonly used in tumble dryers, etc.

Filter G4 (Mod96)	Art.no.
FLK 100	1250200
FLK 125	1250201
FLK 150/160	1250202
FLK 200	1250203
FLK 250	1250204
FLK 315	1250205
FLK 400	1250206

Filterbox	Art.no.
FLK 100 incl. G4	8100002
FLK 125 incl. G4	8100004
FLK 150 incl. G4	8100019
FLK 160 incl. G4	8100006
FLK 200 incl. G4	8100008
FLK 250 incl. G4	8100010
FLK 315 incl. G4	8100012
FLK 400 incl. G4	8100014



Cleanable filter	Art.no.
FLK 100	1250142
FLK 125	1250143
FLK 150/160	1250144
FLK 200	1250145

PRESSURE DROP G4-FILTER

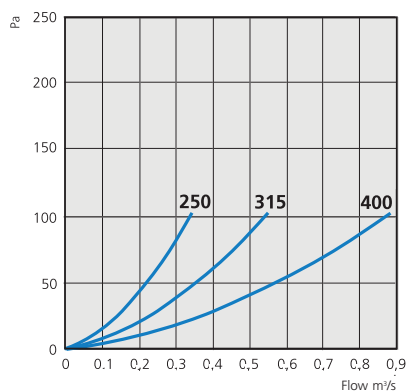
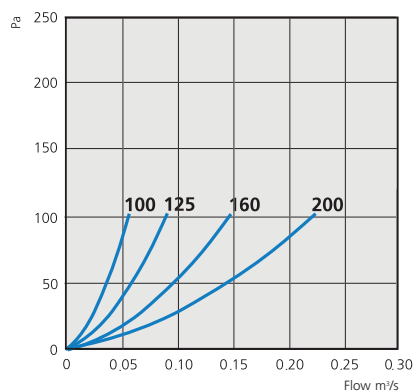

DIMENSIONS (mm)

Type	A	B	Ø	C	D
FLK 100	170	205	100	227	120
FLK 125	205	215	125	252	140
FLK 160	235	265	160	267	155
FLK 200	275	315	200	302	180
FLK 250	325	365	250	352	230
FLK 315	390	425	315	452	320
FLK 400	495	515	400	587	455

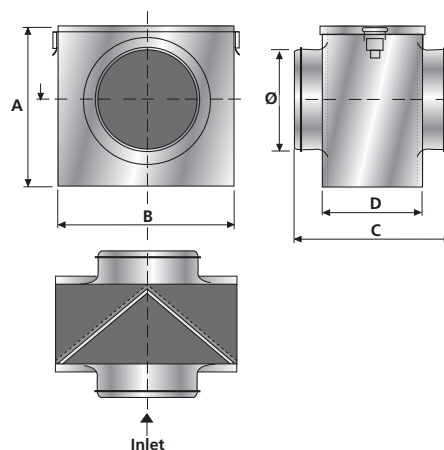

MECHANICAL ACCESSORIES

FILTERBOXES AND FILTERS



Filterbox	Art.no.
FLF 100 excl. filter	8100037
FLF 125 excl. filter	8100038
FLF 160 excl. filter	8100039
FLF 200 excl. filter	8100040
FLF 250 excl. filter	8100041
FLF 315 excl. filter	8100042
FLF 400 excl. filter	8100043

FILTERBOX, FLF

The FLF filterbox is manufactured from galvanized steel sheet. It is delivered without filter.

BAGFILTER, FLF

The FLF bagfilters are to be used in the FLF filter boxes. There are three different filter classes to choose from: G4, F5 and F7, where F7 is the finest.

Bagfilter G4 (Mod97)	Art.no.
FLF 100, 196x163x330/1	1250067
FLF 125, 206x198x330/1	1250070
FLF 160, 256x228x350/2	1250073
FLF 200, 306x268x400/2	1250076
FLF 250, 356x318x460/3	1250079
FLF 315, 416x383x515/3	1250082
FLF 400, 506x488x515/3	1250085

Bagfilter F5 (Mod97)	Art.no.
FLF 100, 196x163x330/2	1250068
FLF 125, 206x198x330/2	1250071
FLF 160, 256x228x350/2	1250074
FLF 200, 306x268x400/2	1250077
FLF 250, 356x318x460/3	1250080
FLF 315, 416x383x470/4	1250083
FLF 400, 506x488x530/4	1250086

Bagfilter F7 (Mod97)	Art.no.
FLF 100, 196x163x330/3	1250069
FLF 125, 206x198x330/3	1250072
FLF 160, 256x228x350/3	1250075
FLF 200, 306x268x400/4	1250078
FLF 250, 356x318x460/6	1250081
FLF 315, 416x383x470/6	1250084
FLF 400, 506x488x530/6	1250087

PRESSURE DROP G4-FILTER

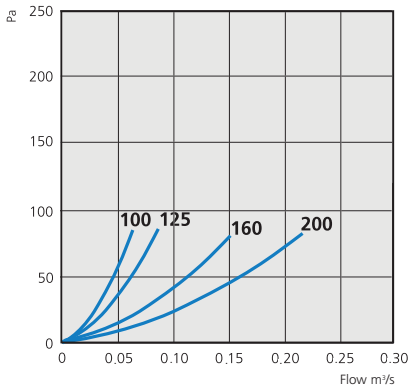

PRESSURE DROP F5-FILTER

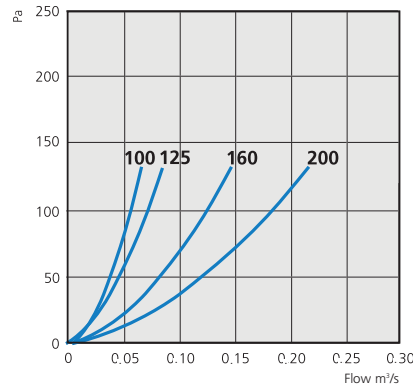

PRESSURE DROP F7-FILTER

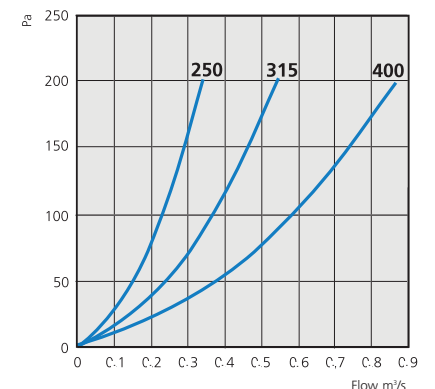
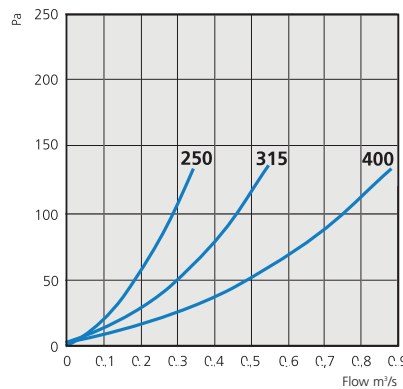
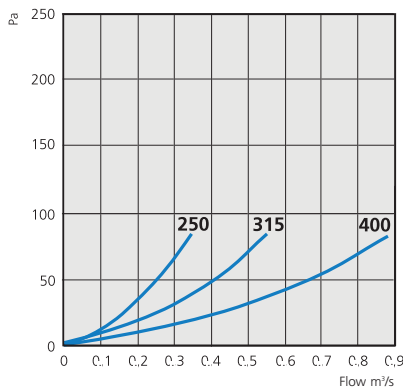
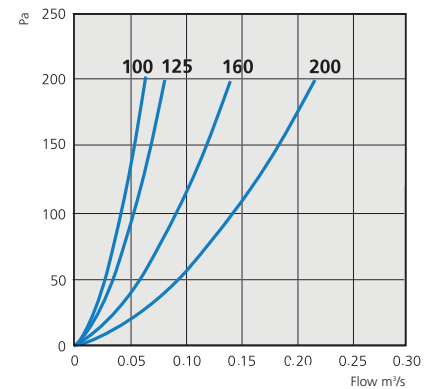

DIMENSIONS (mm)

Type	A	B	Ø	C	D
FLF 100	170	202	100	530	430
FLF 125	205	212	125	535	430
FLF 160	235	262	160	555	450
FLF 200	275	312	200	620	500
FLF 250	325	362	250	680	560
FLF 315	390	423	315	745	625
FLF 400	495	513	400	765	635

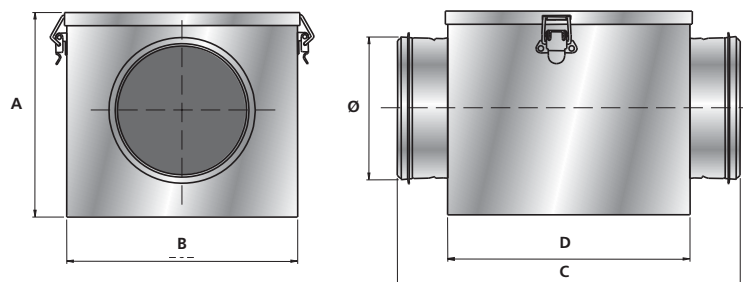

MECHANICAL ACCESSORIES

ASSEMBLY AND INSTALLATION

MOUNTING BRACKET KIT, MB

Mounting bracket kit MB, for easy mounting of CK. The brackets can be mounted anywhere around the joint of the fan.

MB is available in one size and fits all CK.

Type	Art.no.
MB one size for all CK	5190007



MOUNTING BRACKETS UNIVERSAL, KIT

Mounting brackets Universal Kit, for easy mounting of, e.g. RK, RKB, IRB and IRE.

The kit consists of 4 brackets with 8 screws. Max load capacity of the Kit is up to 55 kg.

Type	Art.no.
Mounting brackets Universal Kit	5900006



MOUNTING CLAMP, MK

The fan can be connected to duct with mounting clamp MK. The mounting clamp is made of galvanized steel sheet with a rubber seal to fit tightly and absorb vibrations. The mounting clamp makes the fan easy to remove for cleaning and maintenance.

Available sizes are Ø 100, 125, 150, 160, 200, 250, 300, 315, 400 and 500 mm.

Type	Art.no.
MK 100	9560002
MK 125	9560003
MK 150	9560004
MK 160	9560005
MK 200	9560006
MK 250	9560007
MK 315	9560008
MK 400	9560009
MK 500	9560010



SAFETY GRILLE, BSV

BSV is a safety grille with angled lugs for mounting on ducts. Should also be used on fans that are not connected to ducts to obtain insulation class IP 44.

BSV is manufactured from galvanized steel mesh and is available in sizes Ø 80, 100, 125, 150, 160, 200, 250, 315, 355, 400, 450, 500, 560, 630, 710 and 800 mm.

Type	Art.no.
BSV 80	9520001
BSV 100	9520002
BSV 125	9520003
BSV 150	9520004
BSV 160	9520005
BSV 200	9520008
BSV 250	9520011
BSV 315	9520014
BSV 355	9520016
BSV 400	9520017
BSV 450	9520042
BSV 500	9520043
BSV 560	9520044
BSV 630	9520045
BSV 710	9520050
BSV 800	9520051

SAFETY GRILLE, BSR

BSR is a safety grille with straight lugs for mounting on flat surfaces. Should also be used on fans that are not connected to ducts to obtain insulation class IP 44. It is manufactured from galvanized steel mesh and is available in sizes Ø 100, 125, 160, 200, 250, 270, 315, 355 and 400 mm.

Type	Art.no.
BSR 100	9520060
BSR 125	9520061
BSR 160	9520006
BSR 200	9520007
BSR 250	9520010
BSR 315	9520053
BSR 355	9520015
BSR 400	9520059

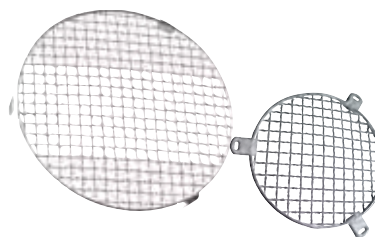

ASSEMBLY AND INSTALLATION

PRESSURE DROP

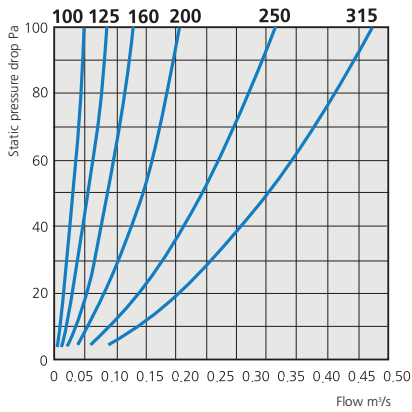

LOUVRE, YG

The YG louvre is manufactured from 4 mm thick die-cast aluminium. The louvre is designed for outdoor use, and is equipped with a fine meshed net as standard. YG has a circular duct connection. YG is available in sizes Ø 100, 125, 160, 200, 250 and 315 mm.

Type	Art.no.
YG 100	9540035
YG 125	9540036
YG 160	9540037
YG 200	9540038
YG 250	9540039
YG 315	9540040

PRESSURE DROP

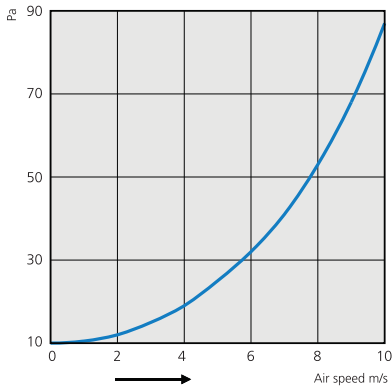

LOUVRE SHUTTERS, VK

VK self-closing louvre shutters are manufactured from UV-resistant material. They are characterized, among other things, by a very low airflow resistance. For example 10 Pa at 4 m/s air speed, 30 Pa at 6.5 m/s and 50 Pa at 8.5 m/s.

Type	Art.no.
VK 100	9520019
VK 125	9520020
VK 160	9520021
VK 200	9520022
VK 250	9520023
VK 300	9520024
VK 355	9520025
VK 400	9520026
VK 450	9520027
VK 500	9520028
VK 630	9520046
VK 710	9520047
VK 800	9520048
VK 900	9520049

DIMENSIONS VK 160-900 (mm)

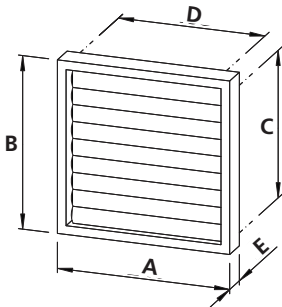

Type	A	B	C	D	E
VK 160	190	190	131	131	25
VK 200	240	240	167	193	28
VK 250	290	290	217	243	28
VK 300	340	340	267	293	28
VK 355	390	390	317	343	28
VK 400	440	440	367	393	28
VK 450	490	490	417	443	30
VK 500	540	540	467	493	30
VK 630	686	690	630	520	40
VK 710	785	785	685	771	40
VK 800	876	885	785	862	40
VK 900	1026	985	885	1012	40

DIMENSIONS VK 100-125 (mm)

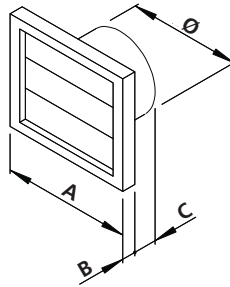

Type	Ø	A	B	C
VK 100	98	140	15	28
VK 125	120-125	160	20	30

MECHANICAL ACCESSORIES

ASSEMBLY AND INSTALLATION

BACKDRAUGHT SHUTTER, RSK

RSK is used for circular ducts and is made from galvanized steel with spring-loaded lamina from aluminium. RSK is available in sizes Ø 100, 125, 150, 160, 200, 250, 315, 355, 400, 450, 500, 560 and 630 mm.

Type	Art.no.
RSK 100	9520029
RSK 125	9520030
RSK 150	9520031
RSK 160	9520032
RSK 200	9520033
RSK 250	9520034
RSK 315	9520035
RSK 355	9520062
RSK 400	9520063
RSK 450	9520064
RSK 500	9520065
RSK 560	9520066
RSK 630	9520067



TECHNICAL DATA

Max. temperature 60°C

PRESSURE DROP

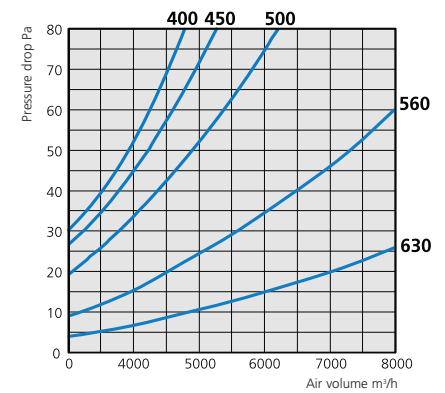
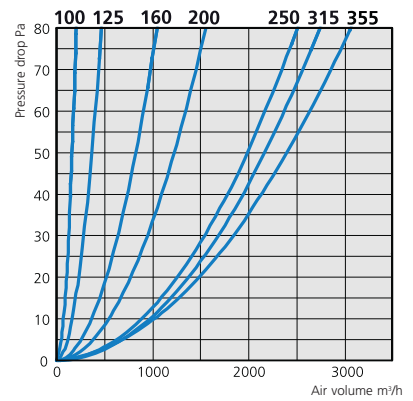

EXHAUST DIFFUSER, LK

LK with lockable settings are made of powder coated sheet steel (colour RAL 9010). Sizes available are Ø 100, 125, 160 and 200 mm. Excl. assembly frame.

Type	Art.no.
LK 100	9540047
LK 125	9540048
LK 160	9540049
LK 200	9540050

INLET DIFFUSER, KE

KE with lockable settings are made of powder coated sheet steel (colour RAL 9010). Sizes available are Ø 100, 125, 160 and 200 mm. Incl. assembly frame.

Type	Art.no.
KE 100	9540051
KE 125	9540052
KE 160	9540053
KE 200	9540054



REDUCING SOCKET, RCFU

For easy change from one duct size to an alternative size. Manufactured from galvanized steel sheet.

Type	Art.no.
RCFU 125 to size 100 mm	9540041
RCFU 160 to size 125 mm	9540007
RCFU 200 to size 125 mm	9540008
RCFU 200 to size 160 mm	9540009
RCFU 250 to size 160 mm	9540055
RCFU 250 to size 200 mm	9540010

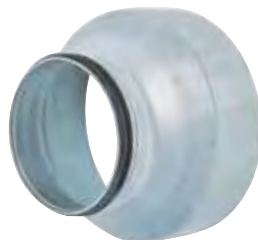

OUTLET FLANGES

Outlet flanges for RFE and DFE. Made from galvanized steel.

Type	Art.no.
RFE 120 MUU/MKU	1200004
DFE 133-21	1200012

ASSEMBLY AND INSTALLATION

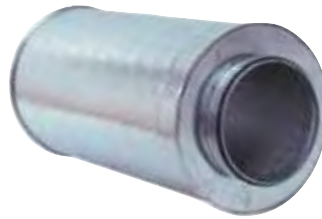

SILENCER, LDC

LDC is a circular silencer with lengths 600 mm or 900 mm in each size. The silencer consists of a perforated duct inside, end caps and outer casing, all of galvanized steel. The intervening space is filled with 50 mm stone wool insulation. Available in sizes Ø 100, 125, 150, 160, 200, 250 and 315 mm.

SOUND ATTENUATION

Dimension x length	Weight, kg	63Hz	125Hz	250Hz	500Hz	1kHz	2kHz	4kHz	8kHz
LDC 100 x 600 mm	4.1	4	8	14	29	34	41	45	25
LDC 100 x 900 mm	6.6	8	9	19	36	48	50	50	28
LDC 125 x 600 mm	4.6	3	7	12	26	28	37	38	22
LDC 125 x 900 mm	7.7	5	7	17	33	40	48	43	24
LDC 150 x 900 mm	8.0	3	7	13	29	36	47	37	21
LDC 160 x 600 mm	5.7	2	5	10	22	23	33	30	19
LDC 160 x 900 mm	8.9	3	7	13	29	36	47	37	21
LDC 200 x 600 mm	7.2	1	5	9	20	22	29	25	18
LDC 200 x 900 mm	10.2	2	6	12	26	31	44	31	20
LDC 250 x 600 mm	8.8	0	3	8	17	21	24	20	17
LDC 250 x 900 mm	12.5	1	4	10	22	27	39	25	19
LDC 315 x 600 mm	10.2	0	4	7	13	20	20	17	16
LDC 315 x 900 mm	15.6	0	5	9	18	23	32	20	18

Type	Art.no.
LDC 100x600 A30	9530002
LDC 100x900 A30	9530003
LDC 125x600 A30	9530004
LDC 125x900 A30	9530005
LDC 160x600 A30	9530008
LDC 160x900 A30	9530009
LDC 200x600 A30	9530010
LDC 200x900 A30	9530011
LDC 250x600 A30	9530012
LDC 250x900 A30	9530013
LDC 315x600 A30	9530014
LDC 315x900 A30	9530015

Type	Weight, kg
300x150	3.0
400x200	4.0
500x250	5.0
600x300	6.0
600x350	6.3
700x400	7.3
800x500	8.6
1000x500	10.0



FLEXIBLE CONNECTION

Rectangular flexible connection for reducing vibration in ventilation systems. With spigot connection. Manufactured from aluminum profiles with aluminum corners and cloth in PVC. Temperature range -25°C - +70°C.

Type	Art.no.
FLEXIBLE CONNECTION 300x150	9540315
FLEXIBLE CONNECTION 400x200	9540420
FLEXIBLE CONNECTION 500x250	9540525
FLEXIBLE CONNECTION 600x300	9540630
FLEXIBLE CONNECTION 600x350	9540635
FLEXIBLE CONNECTION 700x400	9540740
FLEXIBLE CONNECTION 800x500	9540850
FLEXIBLE CONNECTION 1000x500	9541050

DIMENSIONS (mm)

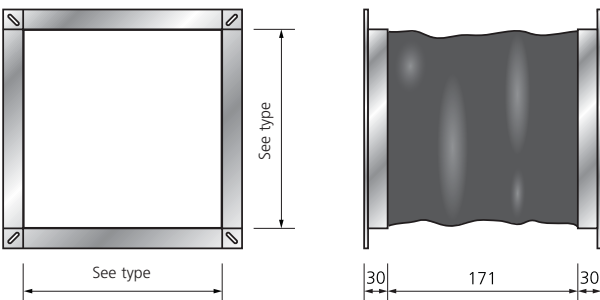

Max. construction dimensions 205 mm.
Recommended application area 160-200 mm.

Type	Art.no.
RK Kit, RKC 160 (RK 300x150)	7600018
RK Kit, RKC 200 (RK 400x200)	7600001
RK Kit, RKC 250 (RK 500x250)	7600002
RK Kit, RKC 315 (RK 500x300)	7600003
RK Kit, RKC 315 (RK 600x300)	7600004
RK Kit, RKC 355 (RK 600x350)	7600005
RK Kit, RKC 400 (RK 700x400)	7600006
RK Kit, RKC 500 (RK 800x500)	7600007
RK Kit, RKC 500 (RK 1000x500)	7600008

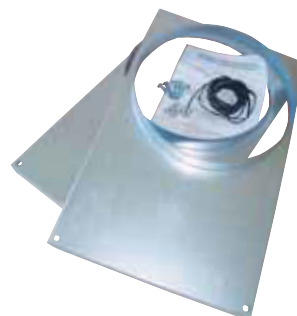

RK CONVERSION KIT

RK Kit to convert RK into RKC, circular duct connection. Contents:
 • 2 sections with circular connection
 • 8 screws M8 x 20 incl. nuts
 • Sealing strip 5 x 10 mm
 • Assembly instruction



MECHANICAL

FILTERBOXES AND FILTERS.....	376
ASSEMBLY AND INSTALLATION	378

ELECTRICAL

CONTROLLERS AND REGULATORS	384
SENSORS	388
TIMERS	389
MOTOR PROTECTION.....	390

FOR ATEX

FOR ATEX CERTIFIED FANS.....	392
------------------------------	-----

FOR ROOF FANS

ROOF CURBS.....	396
-----------------	-----

CONTROLLERS AND REGULATORS

TRANSFORMER CONTROLLER, VRTE, FOR AC MOTORS

For manual 5-step voltage control of single-phase motors, with 0-position. Regulation controlled by switch at front. Operation Indicator light on the housing. The controller is enclosed in a durable PVC or steel housing.



DIMENSIONS (mm)

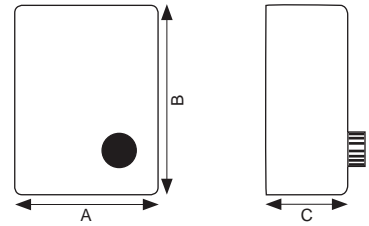

Type	A	B	C	Enclosure
VRTE C	84	160	88	PVC
VRTE 1	115	205	100	PVC
VRTE 3	170	255	140	PVC
VRTE 5	170	255	140	PVC
VRTE 7	200	305	140	PVC
VRTE 13	300	325	185	Steel

Type	Art.no.
VRTE C	8400001
VRTE 1	9500023
VRTE 3	9500029
VRTE 5	9500032
VRTE 7	9500035
VRTE 13	9500040

TECHNICAL DATA

	Voltage V	Current A	Enclosure class	Weight kg
VRTE C	230	1.0	IP 54	1.3
VRTE 1	230	1.5	IP 54	2.1
VRTE 3	230	3.5	IP 54	4.7
VRTE 5	230	5.0	IP 54	5.4
VRTE 7	230	7.5	IP 54	8.0
VRTE 13	230	13.0	IP 54	15.3

OUTGOING VOLTAGES

VRTE C: 80V, 110V, 140V, 170V and 230V

VRTE: 80V, 110V, 140V, 170V, 190V and 230V

WIRING DIAGRAM

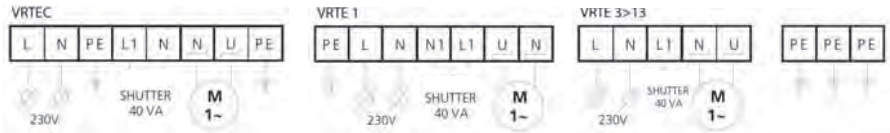

TRANSFORMER CONTROLLER, VRDE, FOR AC MOTORS

A manual 5-step transformer controller with 0-position and high/low speed switch for speed control of voltage controllable single-phase motors. Changeover is done with a potential switch e.g. timer, thermostat or humidistat. Enclosed in a durable PVC or steel housing.



DIMENSIONS (mm)

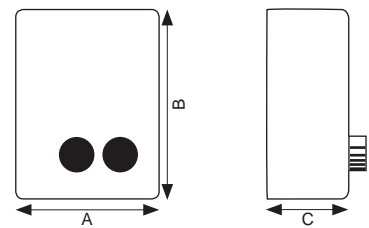

Type	A	B	C	Enclosure
VRDE 1.5	200	305	155	PVC
VRDE 3	200	305	155	PVC
VRDE 7	200	305	155	PVC
VRDE 13	300	425	175	Steel

Type	Art.no.
VRDE 1,5	9500062
VRDE 3	9500028
VRDE 7	9500033
VRDE 13	9500039

TECHNICAL DATA

	Voltage V	Current A	Enclosure class	Weight kg
VRDE 1.5	230	1.5	IP 54	3.9
VRDE 3	230	3.5	IP 54	5.4
VRDE 7	230	7.5	IP 54	8.2
VRDE 13	230	13.0	IP 54	17.6

OUTGOING VOLTAGES

VRDE: 80V, 100V, 120V, 150V, 170V, 190V and 230V

WIRING DIAGRAM

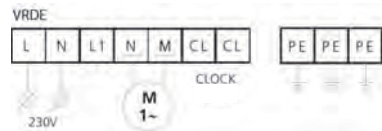

CONTROLLERS AND REGULATORS

DIMENSIONS (mm)

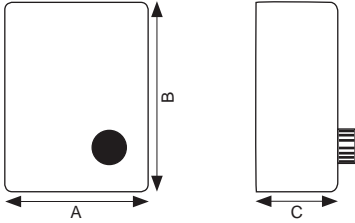

TRANSFORMER CONTROLLER, VRTT, FOR AC MOTORS

For speed control of voltage controllable 3-phase motors. The thermal contact relays are connected to the motor's protracted thermal contact conductor. VRTT breaks the current when the motor gets overheated (It's reset when the motor has cooled down and the switch is in 0-position). The controller is enclosed in a durable steel housing.

Type	A	B	C	Enclosure
VRTT 1	300	325	175	Steel
VRTT 2	300	325	175	Steel
VRTT 4	300	425	175	Steel
VRTT 7	300	425	235	Steel
VRTT 11	400	430	235	Steel

OUTGOING VOLTAGES

VRTT: 95V, 145V, 185V, 240V and 400V

Type	Art.no.
VRTT 1	9500025
VRTT 2	9500027
VRTT 4	9500031
VRTT 7	9500036
VRTT 11	9500038

WIRING DIAGRAM

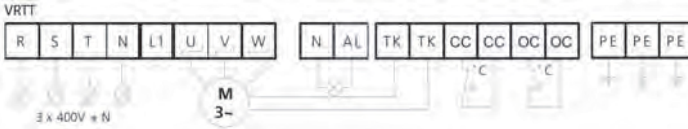

TECHNICAL DATA

	Voltage V	Current A	Enclosure class	Weight kg
VRTT 1	400	1.5	IP 54	12.3
VRTT 2	400	2.5	IP 54	13.4
VRTT 4	400	4.0	IP 54	18.6
VRTT 7	400	8.0	IP 54	27.9
VRTT 11	400	11.0	IP 54	37.8

DIMENSIONS (mm)

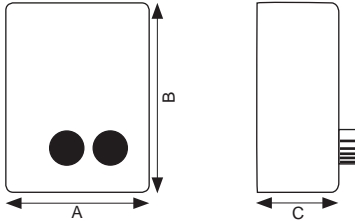

TRANSFORMER CONTROLLER, VRDT, FOR AC MOTORS

A manual 5-step transformer controller with 0-position and high/low speed switch for speed control of voltage controllable 3-phase motors. Changeover is done with a potential switch e.g. timer, thermostat or humidistat. The thermal contact relays are connected to the motor's protracted thermal contact conductor. VRDT breaks the current when the motor gets overheated (It's reset when the motor has cooled down and the switch is in 0-position). Enclosed in a durable steel housing.

Type	A	B	C	Enclosure
VRDT 2	300	325	175	Steel
VRDT 4	300	425	225	Steel
VRDT 7	400	425	225	Steel
VRDT 11	400	430	235	Steel

OUTGOING VOLTAGES

VRDT: 95V, 145V, 185V, 240V and 400V

Type	Art.no.
VRDT 2	9500026
VRDT 4	9500030
VRDT 7	9500034
VRDT 11	9500037

WIRING DIAGRAM

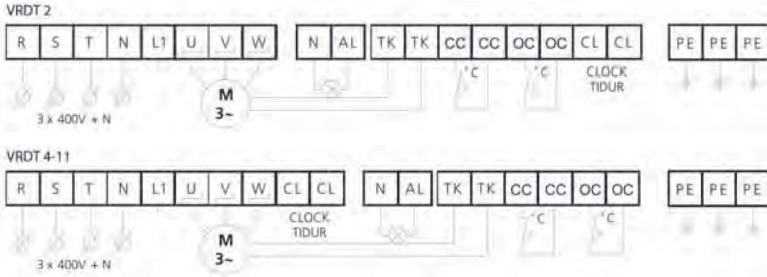

TECHNICAL DATA

	Voltage V	Current A	Enclosure class	Weight kg
VRDT 2	400 V	2.5 A	IP 54	13.7
VRDT 4	400 V	4.0 A	IP 54	20.8
VRDT 7	400 V	8.0 A	IP 54	30.7
VRDT 11	400 V	11.0 A	IP 54	37.6

CONTROLLERS AND REGULATORS

SPEED CONTROLLER, VRS, FOR AC MOTORS

For manual variable speed control of single-phase AC motors. Minimum speed is set by means of a screw under the knob. All single-phase fans from Östberg can be regulated with the VRS controller. The controller is certified and approved as conforming to electrical safety and interference regulations on all markets. Suitable for recessed as well as for surface mounting.



Type	Art.no.
VRS 0.5 I Recessed	9500012
VRS 0.5 U Surface mounted	9500013
VRS 1.0 I Recessed	9500014
VRS 1.0 U Surface mounted	9500015
VRS 2.0 I Recessed	9500016
VRS 2.0 U Surface mounted	9500017
VRS 4.0 U Surface mounted	9500018

TECHNICAL DATA

Voltage	230 V
Current	0.5, 1.0, 2.0 resp. 4.0 A
Enclosure class	IP 54

WIRING DIAGRAM

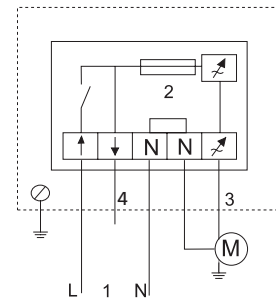

DIMENSIONS (mm)

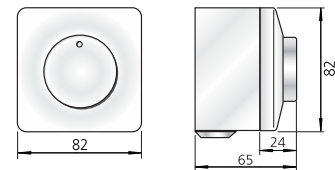

SPEED CONTROLLER, MS EC, FOR EC MOTORS

For manual variable speed control of EC motors. All fans with EC-motors from Östberg have 10 Vdc output that can be connected as supply to the controllers. On the stepless control, Max and Min-mode can be set by adjustment screws under the knob. On controllers with fixed locations, Pos. 1 and Pos. 2 are set by adjusting screws. The controller is certified and approved as conforming to electrical safety and interference regulations on all markets.



Type	Art.no.
MS EC Stepless pot. Off-pos.	9500120
MS EC Steps 1-3	9500121
MS EC Steps 0-3 Off-pos.	9500122
Potentiometer for inst. in junction box	4020443

TECHNICAL DATA

Voltage	10 Vdc
Current	1 mA
Enclosure class	IP 54

WIRING DIAGRAM

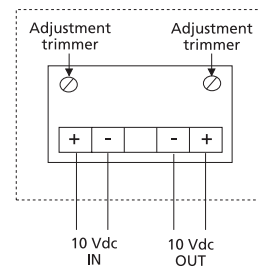

DIMENSIONS (mm)

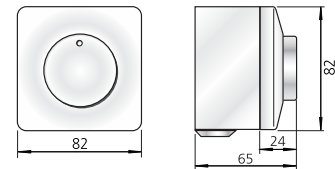

PRESSURE REGULATOR

The accessory pressure regulator Calair-PR-230V measures differential pressure and controls ventilation system fans via a 0-10V signal. Two digital inputs can be used, for example for monitoring a fan motor and activation of other setpoints. The pressure regulator can be read and programmed via Modbus RS485. Calair PR 230 is also equipped with an alarm log where the last ten alarms are recorded and saved.



Type	Art.no.
Pressure regulator with Modbus	9500123
Outdoor temperature sensor	9500124

TECHNICAL DATA

Supply voltage	230 V +10%
Frequency	500 Hz
Output signal	0-10V
Pressure range	0-2000 Pa
Speed (baud, rate, kbps)	9.6/19.2/38.4/57.6/115.2
Enclosure class	IP 54
Dimensions	109 x 195 x 52 mm

WIRING DIAGRAM

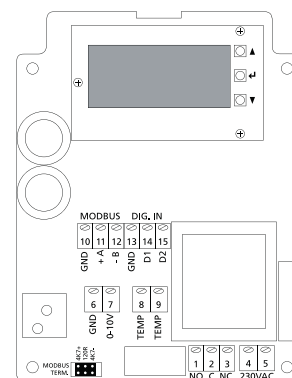

CONTROLLERS AND REGULATORS

TECHNICAL DATA

Breaking capacity	5 A, 250 V AC, variable switch
Setting range	20-200 Pa, 20-300 Pa, 50-500 Pa
Pressure settings	20-70 Pa
Temperature range	-20 °C - +85 °C
Max. diff. pressure	5000 Pa
Enclosurr class	IP 54
Connections	6 mm

WIRING DIAGRAM

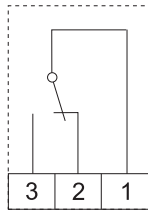

PRESSURE SWITCH, DTV

Pressure switch to monitor air handling units. DTV is used e.g. to monitor the fans and filters. Switching points are easily set inside the sensor.

Type	Art.no.
20-200 Pa	9500067
50-500 Pa	9500001
20-300 Pa DTV 200	9500099
Pressure switch Kit	9500105

TECHNICAL DATA

Breaking capacity	5 A 250 V AC variable switch
Humidity range	35-95% RH
Accuracy	+/- 4% RH
Max temperature	40 °C
Air speed	Max 1.5 m/s
Enclosure class	IP 30
Dimensions	86 x 86 x 30 mm

WIRING DIAGRAM

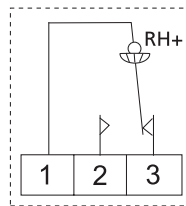

ROOM HUMIDISTAT, HR-S

HR-S is used to control the fans according to relative humidity. HR-S has a new synthetic sensor element that provides high accuracy. The set point can be anywhere between 35-95% RH.

Type	Art.no.
HR-S	9500060

TECHNICAL DATA

Voltage	230 V AC, +/-15%, 50-
Power	Max 3680 W (16 A)
Temperature range	0-30°C
Accuracy	1°C
Enclosure class	IP 20
Dimensions	86 x 86 x 30 mm

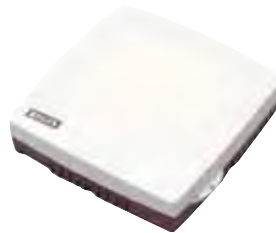

ROOM THERMOSTAT, TM1

TM1 is a single-step room thermostat with a change-over relay for either heating or cooling. TM1 may be used with the internal or an external sensor. If the TM1 is used with the internal sensor. It should be mounted approx. 1.5 meters above floor level. Temperature range is 0-30° C.

Type	Art.no.
TM 1	9520036

ELECTRICAL ACCESSORIES

SENSORS

PUKSER

Pulser is a complete proportional controller for electric heating (time proportional). PULSER can be connected to single or 2-phase voltage and has a built-in sensor and set point adjustment.
Max outputs 3.6 kW (230 V) or 5.4 kW (400 V).

Type	Art.no.
Pulser 230/400 V	9510032



WIRING DIAGRAM

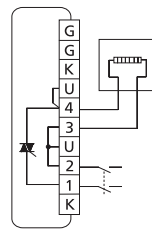

TECHNICAL DATA

Voltage	210-415 V
Frequency	50/60 Hz
Max. output	16 A
Pulse period	60 sek
Enclosure class	IP 30
Weight	0.3 kg
Dimensions	94 x 150 x 43 mm

DUCT SENSOR

For measuring air temperature in ventilation ducts. Intended for use with PULSER to maintain the desired ventilation air temperature. The sensor has adjustable insertion length and is delivered with 1.5 m cable.

Type	Art.no.
Duct sensor TGK 330	9510079



DIMENSIONS (mm)

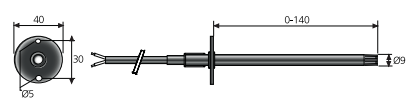

TECHNICAL DATA

Temperature range	0 - +30°C
Enclosure class	IP 20

ROOM SENSOR

For measuring air temperature in room.

Type	Art.no.
Room sensor TG-R530	9510037



TECHNICAL DATA

Enclosure class	IP 20
Dimensions	86 x 86 x 30 mm

ELECTRIC DUCT HEATER, CV

The CV electrical duct heater is manufactured from galvanized steel sheet with stainless steel elements. It is equipped with a bipolar overheating protection. The duct heater can be used with Pulser and a room or duct sensor.

Type	Art.no.
CV 125 0.9 kW	9510004
CV 160 0.9 kW	9510065
CV 160 1.5 kW	9510016
CV 160 2.1 kW	9510010
CV 160 5.0 kW	9510028
CV 200 0.9 kW	9510049
CV 200 1.5 kW	9510011
CV 200 2.1 kW	9510012
CV 200 6.0 kW	9510030
CV 250 0.9 kW	9510050
CV 250 1.5 kW	9510015
CV 250 2.1 kW	9510013
CV 250 6.0 kW	9510017
CV 315 2.1 kW	9510014
CV 315 6.0 kW	9510043
CV 315 9.0 kW	9510098



DIMENSIONS (mm)

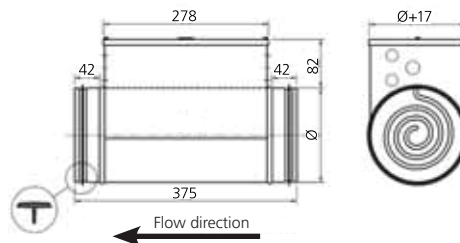

TECHNICAL DATA

Min. air speed: 1.5 m/s			
Ø mm	Voltage/phase	Power	Min. flow
125	230V/~	0.9 kW	70 m³/h
160	230V/~	0.9 kW	110 m³/h
160	230V/~	1.5 kW	110 m³/h
160	230V/~	2.1 kW	110 m³/h
160	400V/2~	5.0 kW	110 m³/h
200	230V/~	0.9 kW	170 m³/h
200	230V/~	1.5 kW	170 m³/h
200	230V/~	2.1 kW	170 m³/h
200	400V/2~	6.0 kW	170 m³/h
250	230V/~	0.9 kW	270 m³/h
250	230V/~	1.5 kW	270 m³/h
250	230V/~	2.1 kW	270 m³/h
250	400V/2~	6.0 kW	270 m³/h
315	230V/~	2.1 kW	415 m³/h
315	400V/2~	6.0 kW	415 m³/h
315	400V/2~	9.0 kW	415 m³/h

WIRING DIAGRAM

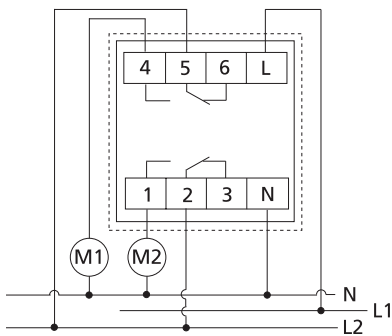

TECHNICAL DATA

Max. power	16 A
Time resolution	1 minute
Accuracy	<1s per day
Battery	6 year, lithium
Enclosure class	IP 20

WEEK TIMER

2-channel electronic week timer for DIN rail mounting. Daily or weekly programs, and automatically adjusts for daylight savings time. 4 year power reserve. 42 memory cells. Programming is done by free alignment, which means that days with different switching times only use one memory cell. The enclosure enables the week timer to be used in an IP 30 or 54 environments.

Type	Art.no.
Week timer TR 610 S	9500046
Enclosure (IP30)	9500047
Enclosure (IP 55)	9500048

TECHNICAL DATA

Voltage	230 V
Frequency	50 Hz
Max. power	10 A
Lagging current	2.5 A
Switch	Single pole, relay
Dimensions	84x84x43 mm



ELECTRONIC TIMER

Two options are available: 1-120 minutes or 1-8 hours. Running time is chosen during installation. Pushing the button once activates the timer, and a second push turns it off. LED indicates when it is active. The electronic timer is not compatible with the transformers VRDE or VRDT. The extension frame is intended for use with the electronic timer when surface wall mounted.

Type	Art.no.
Timer 1 - 120 min.	9500057
Timer 1 - 8 hours.	9500049
Extension frame	9500050

TECHNICAL DATA

Voltage	230 V
Frequency	50 Hz
Max. power	2.5 A
Switch	Breaking/change-over
Enclosure class	IP 44
Dimensions	80x80x70 mm



TIMER 120

Timer 120 is available with breaking or change-over switches. Timer 120 with change-over switch can be used with our transformers VRDE and VRDT. Maximum time is 120 minutes, and they are available for recessed or surface wall mounting.

Type	Art.no.
Timer 120. Type I (recessed)	9500004
Timer 120. Type I (change over) (recessed)	9500005
Timer 120. Type U (surface)	9500006
Timer 120. Type U (change over) (surface)	9500007

MOTOR PROTECTION

THERMAL CONTACT RELAY, TFE AND TFA

The thermal contact relay is used for motors with protracted thermal contact conductors, and disconnects main supply if the motor's thermal contacts are open. Available with or without indicator for triggered thermal contact.

The thermal contact on the motor automatically resets when the motor has cooled, but the thermal contact relay must be reset manually by pressing the black button.

TFE for single phase motors 230V 0.4-10.0 A.

TFA for 3-phase motors 400V 0.1-25.0 A.

The enclosure fits the thermal contacts TFA and TFE.

It enables the TFE and TFA to be used in an IP 55 environment.



WIRING DIAGRAM TFE

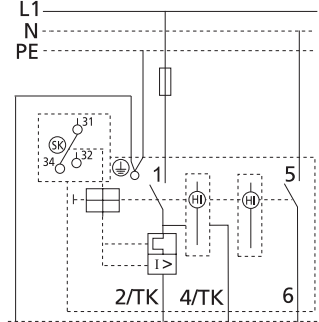

WIRING DIAGRAM TFA

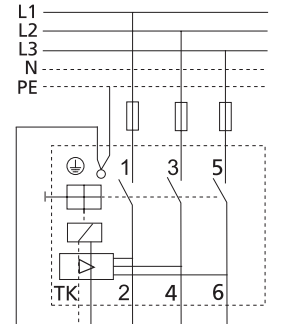

Type	Art.no.
TFE 0.40-10 A, 1-phase	
Without indicator	9500052
With indicator	9500054
TFA 0.10-25 A, 3-phase	
Without indicator	9500053
With indicator	9500055
Enclosure for TFE and TFA (IP 55)	9500056

DIMENSIONS (mm)

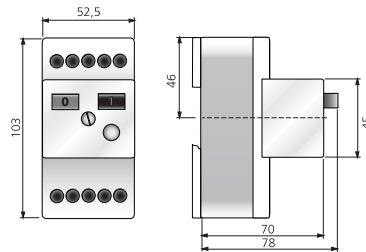

ENCLOSURE

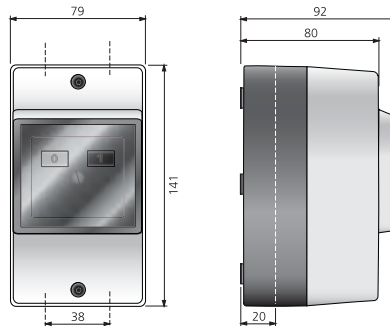

MECHANICAL

FILTERBOXES AND FILTERS..... 376
ASSEMBLY AND INSTALLATION 378

ELECTRICAL

CONTROLLERS AND REGULATORS 384
SENSORS 388
TIMERS 389
MOTOR PROTECTION..... 390

FOR ATEX

FOR ATEX CERTIFIED FANS..... 392

FOR ROOF FANS

ROOF CURBS..... 396

ACCESSORIES ATEX

FOR ATEX CERTIFIED FANS

JUNCTION BOX FOR RKX

ATEX-approved junction box for RKX in black fiberglass-reinforced polyester casing.

Type	Art.no.
Junction box ATEX	4020333

TECHNICAL DATA

Ex. II 2 G/D, Ex. e II T6, Ex. tD A21 IP65 T80°C	
Type of certification	TPS 07 ATEX 61951 1
Rated voltage	550 V
Rated current	6 A
Temperature range	-40- +60°C
Enclosure class	IP 65
Max. number of terminals	10 x 2.5 mm ²



WIRING DIAGRAM

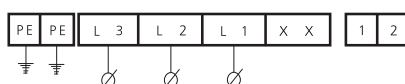

DIMENSIONS (mm)

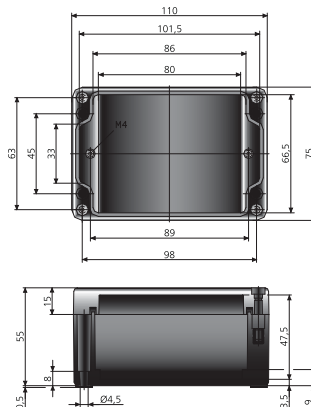

THERMAL CONTACT RELAY FOR RKX

Thermal contact relay designed with corresponding ATEX classification for the ATEX-certified RKX duct fan. It protects motors, transformers, machinery and equipment against overload.

The enclosure is made of fiberglass-reinforced polyester and fits the thermal contact relay. This enclosure enables the relay to be used in an IP 54 environment.

Type	Art.no.
Thermal contact relay Atex	9500108
Enclosure (IP 54)	9500109



DIMENSIONS (mm)

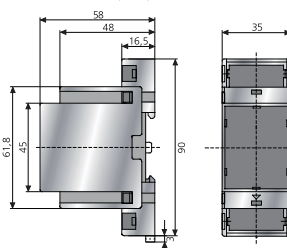

TECHNICAL DATA

Ex II (2) G, ATEX 3045	
Voltage	AC 220-240 V
Frequency	50/60 Hz
Max current	6 A
Breaking capacity	3 A AC15 250 V
Temperature range	-20-+55°C
Enclosure class	IP 20

WIRING DIAGRAM

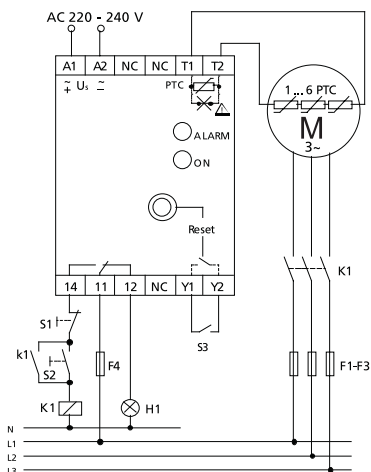

ENCLOSURE

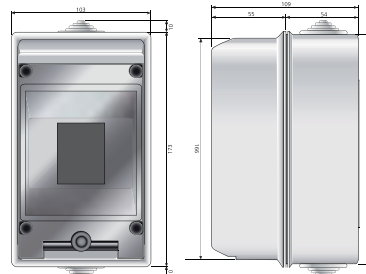

FOR ATEX CERTIFIED FANS

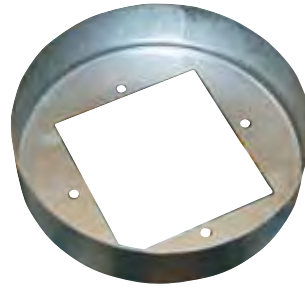

OUTLET FLANGES

Outlet flanges for RFTX for connection to circular duct.
Made from galvanized steel.
Available for RFTX 140, 160 and 200.

Type	Art.no.
RFTX 140 A/C Ø160	1140061
RFTX 160 A/C Ø160	1140062
RFTX 200 A/B Ø200	1140063
RFTX 200 C Ø200	1140064

DIMENSIONS (mm)

140 A/C

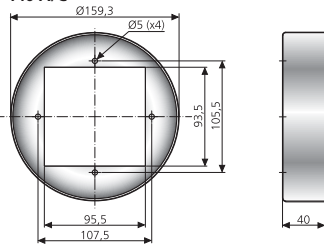

160 A/C

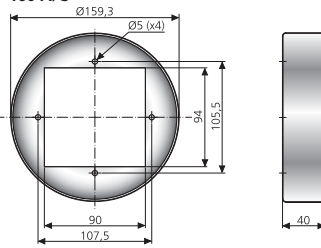

200 A/B

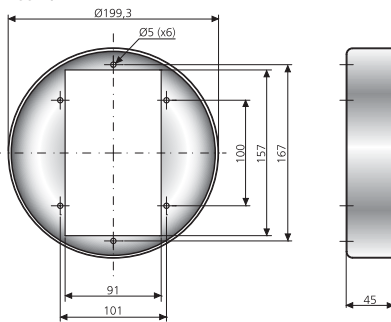

200 C

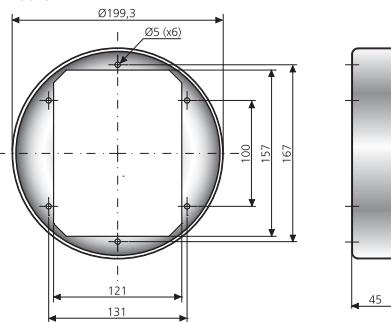

WIRING DIAGRAM

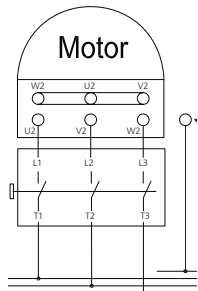

DIMENSIONS (mm)

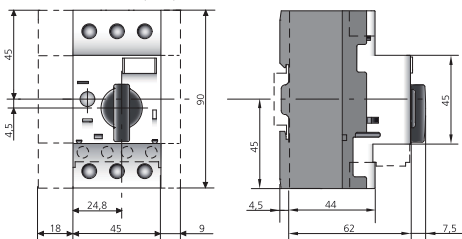

MOTOR PROTECTION

Current sensitive external motor protection with corresponding ATEX classification for the ATEX-certified RFTX radial fan.
It protects motors, transformers, machinery and equipment against overload.

Type	Art.no.
0,40-0,63 A	9500063
0,63-1,00 A	9500064

TECHNICAL DATA

Ex II (2) G, ATEX 3039	
Current range	0.4 - 0.63 A/0.63 - 1.0 A
Voltage	AC 220-240 V
Frequency	50/60 Hz
Max current	8.2/13 A
Temperature range	-25+60°C
Enclosure class	IP 20



MECHANICAL

FILTERBOXES AND FILTERS.....	376
ASSEMBLY AND INSTALLATION	378

ELECTRICAL

CONTROLLERS AND REGULATORS	384
SENSORS	388
TIMERS	389
MOTOR PROTECTION.....	390

FOR ATEX

FOR ATEX CERTIFIED FANS.....	392
------------------------------	-----

FOR ROOF FANS

ROOF CURBS.....	396
-----------------	-----

ROOF CURBS

ROOF CURB, TFU

The acoustic roof curb TFU is intended to be used together with the roof fans TKS and TKV/TKH. The acoustic roof curb TFU is manufactured from galvanized steel sheet and has a sound absorbing insulation, the face of which is coated for ease of cleaning. TFU 300-400 has 50 mm and TFU 560-760 has 120 mm rock wool. TFU 960 has 120 mm rock wool + 50 mm mineral wool insulation. A plastic conduit for the power cable is included as standard. TFU 300-400 is available in two lengths, 600 and 900 mm. TFU 560-660 is available in the lengths 900 and 1200 mm. TFU 760-960 in the length 1200 mm.

Type	Art.no.
TFU 300x600	8200003
TFU 300x900	8200004
TFU 400x600	8200005
TFU 400x900	8200006
TFU 560x900	8200105
TFU 560x1200	8200106
TFU 660x900	8200107
TFU 660x1200	8200108
TFU 760x1200	8200109
TFU 960x1200	8200110



DIMENSIONS (mm)

Type	Dimensions (mm)						Weigt kg
	A	□B	□C	D	E	□F	
TFU 300x 600	600	188	295				10
TFU 300x 900	900	188	295				15
TFU 400x 600	600	289	395				15
TFU 400x 900	900	289	395				21
TFU 560x 900	905	268	512			392	42
TFU 560x1200	1205	268	512			392	53
TFU 660x 900	905	368	612			492	50
TFU 660x1200	1205	368	612			492	64
TFU 760x1200	1205	467	712	472	586		76
TFU 960x1200	1205	567	912	672	786		103

TFU 300 och 400

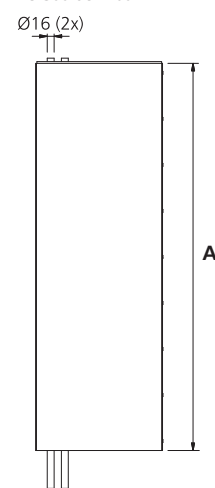

TFU 300

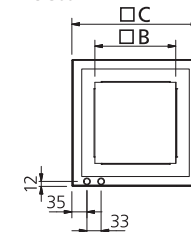

TFU 400

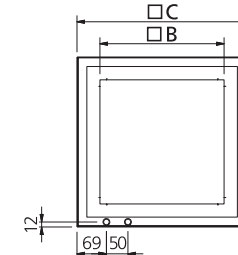

TFU 560 t.o.m. 960

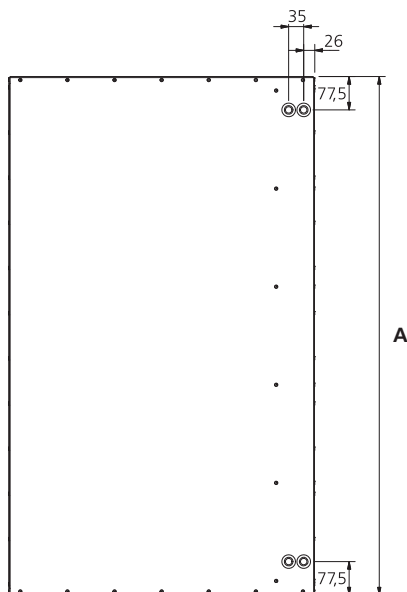

TFU 560 och 660

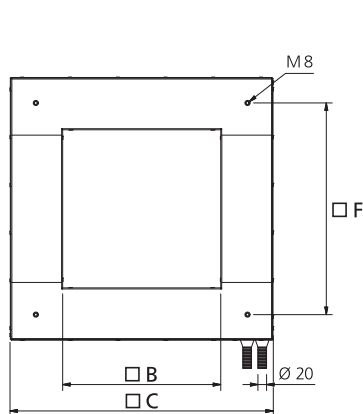

TFU 760 och 960

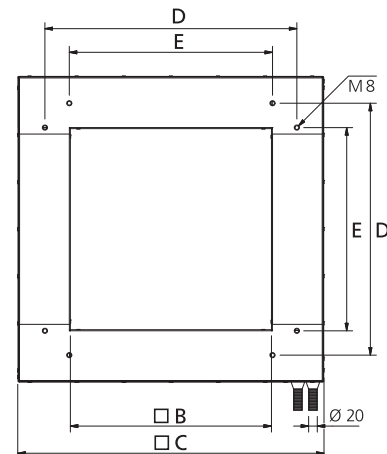

ROOF CURBS

Type	Dimension, mm		Weigt kg
	□ A	∅	
TFU 300	288	160	0.7
TFU 400	388	160	1.3
TFU 400	388	200	1.2
TFU 400	388	250	1.1
TFU 560	440	315	1.6
TFU 660	540	400	2.2
TFU 760	630	500	2.7
TFU 960	830	630	4.4



CONNECTION PLATE FOR TFU

Connection plate with circular connection made from galvanized steel sheet.
Available for all sizes of TFU.

Type	Art.no.
Connection plate TFU 300 with pipe 160	8200041
Connection plate TFU 400 with pipe 160	8200044
Connection plate TFU 400 with pipe 200	8200045
Connection plate TFU 400 with pipe 250	8200042
Connection plate TFU 560 with pipe 315	8200117
Connection plate TFU 660 with pipe 400	8200118
Connection plate TFU 760 with pipe 500	8200119
Connection plate TFU 960 with pipe 630	8200120

DIMENSIONS (mm)

300-400

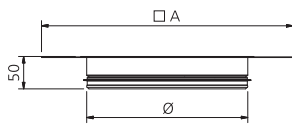
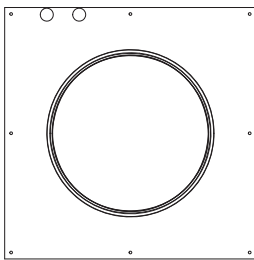

560-960

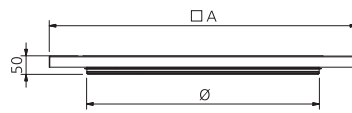
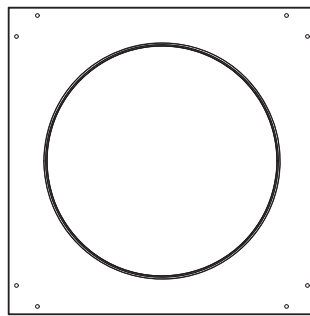

Type	Dimension, mm			Weigt kg
	□ A	B	∅	
TFU 300	288	146	160	1.0
TFU 400	388	185	250	2.0
TFU 560	440	186	315	2.8
TFU 660	540	256	400	3.9
TFU 760	630	306	500	5.9
TFU 960	830	306	630	8.4

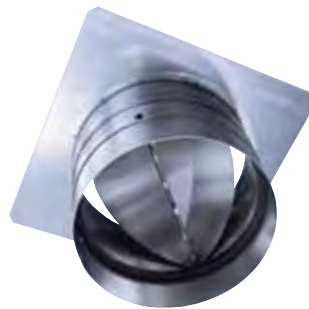

BACK DRAUGHT SHUTTER FOR TFU

A back draught shutter mounted on galvanized steel sheet.
Available for all sizes of TFU.

Type	Art.no.
Back draught shutter TFU 300	8200111
Back draught shutter TFU 400	8200112
Back draught shutter TFU 560	8200113
Back draught shutter TFU 660	8200114
Back draught shutter TFU 760	8200115
Back draught shutter TFU 960	8200116

DIMENSIONS (mm)

300-400

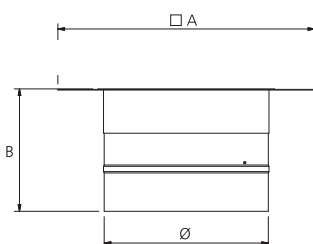
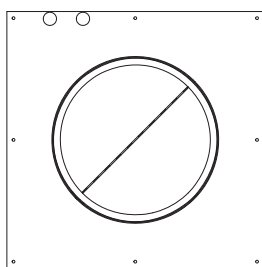

560-960

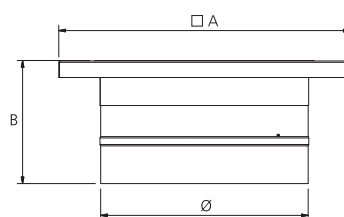
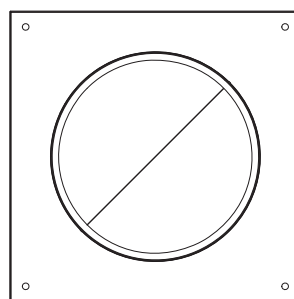

ROOF CURBS

ROOF CURB, TG

The mounting plate, TGÖ, is designed to be used with the roof fan TKC.

TGÖ is manufactured in black polyester plastic coated galvanized steel sheet and is available as plain or profiled. The profiled version is for use with 2-lap concrete roof tiles.

The mounting plate is provided with a "shackle lock" for securing a TKC roof fan (with a circular connection). An electrical outlet with a two-meter cable is included as standard.

The bottom fixing plate, TGU, is manufactured from galvanized sheet steel.

Type	Art.no.
TGÖ Profile without apron. Black	8200015
TGÖ Plain without apron. Black	8200016
TGU inside apron	8200082

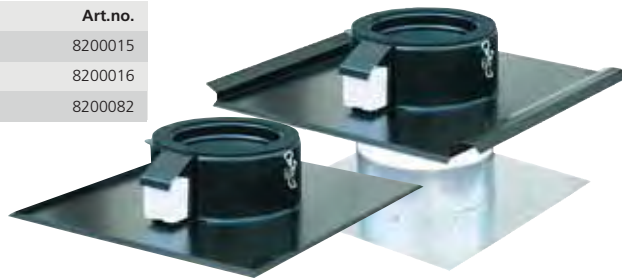

DIMENSIONS (mm)

TGÖ PLAIN

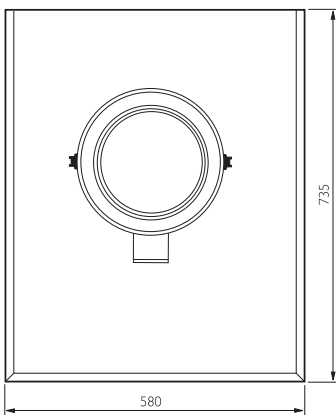
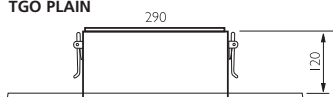

TGÖ PROFILE

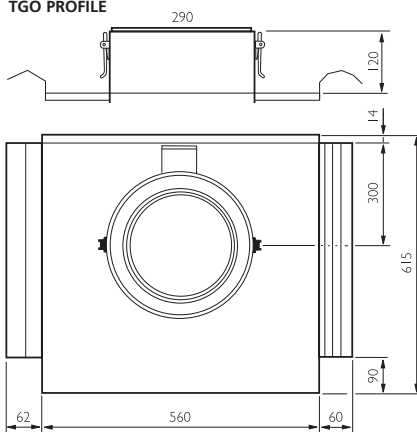

TGU

